

HERZ - Ball valve for water drainage with connection for hose

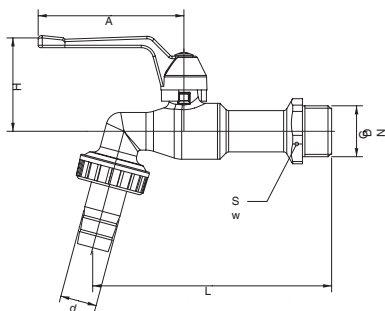

Datasheet 1 2503 0X, Issue 0916

☑ Dimensions



Order Nr.	DN	G	d	L	H	A	Sw	Weight
		(in)	(mm)	(mm)	(mm)	(mm)	(mm)	(kg)
1 2503 01	15	1/2"	15	98	38	60	25	0.192
1 2503 02	20	3/4"	19	103	41	60	30	0.254

☑ Material and construction

Body:	DZR copper alloy, acc. EN 12165, nickel plated, CW617N
Ball:	DZR copper alloy, acc to. EN 12165, full bore, hard chrome plated, CW602N.
Spindle:	Machined DZR copper alloy, acc. to EN 12164, CW614N
Handles:	Lever handle, red, silumin.
Ball seals:	PTFE
Spindle seals:	NBR
Rubber hose connector:	DZR copper alloy, nickel plated.
External thread connectors:	acc. to ISO 228

☑ Operating data

Max. operating pressure:	16 bar
Min. operating temperature:	0 °C (water 0,5°C)
Max. operating temperature:	85°C
Medium:	Potable water

☑ Field of application

Ball valve is used in installations as shut off-valve. In addition, the ball valve can be used for water drainage. Field of application are building services such as portable water systems as well as heating water plants.

☑ Assembly instruction

The threads of the pipe are coated with a suitable sealing material (spinning material, Teflon ribbon, sealing paste). There should not be excess of sealing material on the pipe because it can damage the thread. The ball valve with thread (G) is screwed onto the pipe. When using copper or plastic pipes take into account pressure and temperature limits of used material. When assembling, use a suitable assembly tool that adapts to valve end connections (Sw, Sw1). The ball valve can be mounted in any position: horizontal, vertical or upside-down. Following assembly, the connections of ball valve must be checked for water-tightness by the installer carrying it out. All engineering standards and recognised regulations must be adhered to by these specialist staff. If there are impurities in the medium (water too hard, dust, etc.) there should be a filter installed, in other case the impurities can damage the seals in the valve.

☑ Maintenance instructions

When the HERZ ball valve is installed, it does not require need any special maintenance. It is recommended to close and open the ball valve periodically (at least twice a year).

☑ Disposal instructions:

The disposal of HERZ ball valves must not endanger the health or the environment. National legal regulations for proper disposal of the HERZ ball valves have to be followed.

All specifications and information within this document are reflecting the information available at the time of going to print and meant for informational purpose only. Herz Armaturen reserves the right to modify and change products as well as its technical specifications and/or its function according to technological progress and requirements. All diagrams are indicative in nature and do not to be complete. It is understood that all images of Herz products are symbolic representations and therefore may visually differ from the actual product. Colours may differ due to printing technology used. In case of any further questions don't hesitate to contact your closest HERZ Branch-Office.